

Spring

Instructions for assembly



Introduction	1
Assembly	3
Tips and tricks for using the loom.....	18
Maintenance	20
Troubleshooting	20

Introduction

The parallel countermark system

In a countermark loom, every shaft is actively involved in each shed: Each shaft is either lifted or pulled down by each treadle.

Uneven sheds, for example a satin weave shed, where four shafts are lifted and one is pulled down, open cleanly every time. The warp ends on the fifth shaft do not tend to ride up as they often do with jack looms.

When the shed is made, the same tension is applied to the raised ends as to the lowered ones, resulting in the best shed in relation to the increase of the warp tension.

Traditional countermark system

Look at the diagram to help you understand how a countermark loom works. The points marked S are the pivoting points for the lams C and D and the jacks E.

You will see that beneath each shaft, there are two lams associated with it. One of those lams is directly connected to the shaft and moves in the same direction as it does: when this lam is pulled down, the shaft moves down. When the other lam is pulled down, the shaft rises.

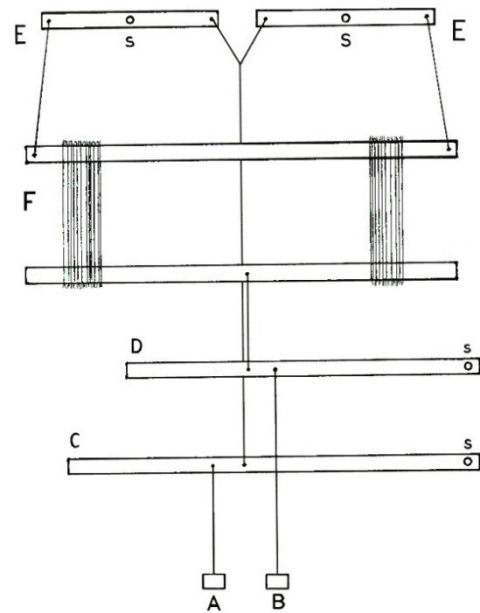

Parallel countermark

Each shaft is attached to a cord, which goes over all six rollers. The ends of the cord are joined, so the cord forms a continuous loop. When treadle A is pressed down, the lower lam C, attached to the outside part of the cord, moves downward, pulling the shaft F up. When treadle B is pressed down, the upper lam D attached to the inside part of the cord, goes down, pulling the shaft with it.

Compared to the traditional countermark, the parallel countermark has five nice features:

1. In contrast to the traditional countermark, the lams of the parallel countermark stay horizontal, while moving the same distance as the shafts. This means that the action of all treadles is the same, not depending on their location in the width of the loom.
2. The parallel countermark system is more compactly constructed, because the action space the lams need is less than pivoting lams and the rollers at the top take less space than jacks.

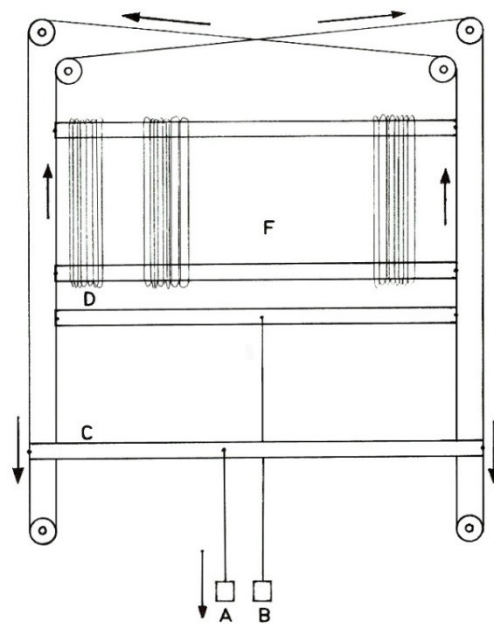

3. Shaft bars and lams cannot slant. Their ends are fixed to the cord and when the cord moves, all parts of the cord have to move the same distance.
4. There is no tie-up to the middle of the lower shaft bars, so the heddles can be moved freely over the shafts.
5. There are no cords, connecting the lams to jacks, running through the middle of the warp

Because each treadle is tied to one of the lams of each shaft, twice as many tie-ups per treadle must be made, on the average, compared to looms with another system.

Before the advent of Texsol cord, the time required to tie up a countermarch loom was daunting. Once the ties were made, there were still problems as knots slipped or had to be untied to adjust the cords. Fortunately this drudgery is a thing of the past. The Texsol cords neither stretch nor require knots. The Texsol tie-up cords are attached to the lams and can be simply hooked onto the treadles. Changing the tie-up is easy and fast.

The moving breast beam

To improve the countermarch shed, to offer the best shed a shaft action system can provide, Louët invented an action system for another part of the loom that holds the warp: the moving breast beam.

This allows the shafts to move more easily in their opposite directions. Looking at the diagram that shows the loom from the side, you will see that a shed is giving the warp a kind of parallelogram shape. Imagine, the warp is made of inelastic material, like metal wire, you will understand that making a shed is only possible if the distance between breast beam and back beam becomes smaller. When this distance is fixed, as it is on other looms, the shed depends completely on the elasticity of the warp. When the shed becomes wider, the tension on the yarns increases (enormously, in case of a less elastic warp). That causes heavy treading and may damage the warp.

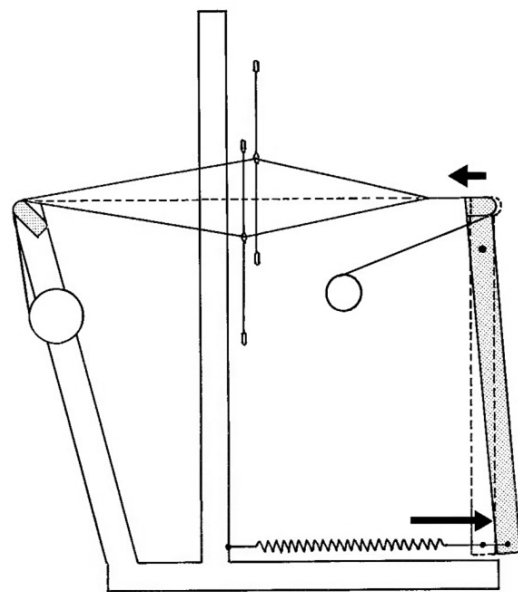

The moving breast beam is held by springs, adjustable to give your warp the tension needed for your project. Besides improvement of the shed and protection of the warp, the springs guarantee exactly the same warp tension each time you have to advance the fabric.

The Texsol system

Texsol cord and heddles are Swedish products, crocheted out of polyester yarn. Cotton heddles have the advantage of being silent in use. Metal heddles, flat or wire, have the advantage of having open eyes. Texsol heddles combine these features. A bundle of Texsol heddles is a continuous line of 100 heddles folded into a zigzag. Each bundle is fastened in four places. These ties make it easy to pass the shaft bars through the upper and lower loop of the heddles. Do not remove the ties from the bundles, until the heddles have been slipped onto the shaft bars or the loops of the bundles are inserted by sticks, to protect the heddles from becoming entangled.

If you need to remove heddles from a shaft, first tie them as they were originally. Use a pair of sharp scissors to cut the heddles apart.

Texsol cord consists of two cords, which are connected every 12 mm, forming loops in between. If needed, the cord should be cut between two loops. To prevent unraveling, the ends should be singed.

Be careful not to overdo the melting and be aware that melted polyester is very hot and will burn the skin.

By mentioning the first or last loop in these instructions, the loop is meant, next to the one where the cord is cut, because when that loop remains after cutting, it has no strength and should not be used.

Assembly

Assembly tips and information

Barrel nuts

For the assembly of the looms, we use barrel nuts and bolts or threaded ends to connect two parts. These cylinder shaped nuts have a slot on one of the flat sides. Always insert the barrel nut into the wooden part, so that the slot in the barrel nut is visible. The slot shows the direction of the threaded hole in the nut. With a flat screwdriver you can turn the barrel nut so that it is positioned properly to catch the bolt. If you have a problem inserting the bolt into the barrel nut, try turning the barrel nut 180 degrees. This usually helps.

Carriage bolts

In other locations, we use carriage bolt to assemble wooden parts. These bolts have a square enlargement (neck) under the bolt head. When you tighten the nut on the bolt, this square neck locks into the wood to prevent the bolt from turning. In some instances, you will notice, that the bolt is just a little too short for assembly with the washer and nut. We advise you to put the nut on the bolt without the washer, and then tighten the nut sufficiently, so that the square neck pulls into the wood. At this stage, unscrew the nut, install the washer and then replace and secure the nut again, tightly. Alternatively, you can carefully tap against the bolt head with a hammer, until the bolt head is secured into the wood.

Washers and spacers

For the proper operation of the loom, it is very important that you follow the correct assembly sequence of the bolts, washers and spacers. Please carefully follow the instructions.

To help you, we have assembled all the washers and spacers in the hardware bags in the right sequence.

Wood screws

Where wood screws are used, we have pre-drilled holes in the wood. The screws will cut their own thread into these holes. Please note however, that the screws are very sharp, and will cut into the full wood outside the pre-drilled holes, if you miss the pre-drilled hole during assembly. However if this happens, you will notice that after a couple of turns, it becomes very hard to turn the screw. There is even a chance that the screw will twist off. Moreover, the parts will be assembled in the wrong location.

If you have to assemble and disassemble the loom several times, make sure that the wood screw turns in the same thread again which was cut the first time. If you do not follow this instruction, the hole in the wood will become too large for the screw. To find this screw thread, turn the screw anti clock wise, until you "feel" the screw "drop" into the threaded part in the wood.

Tools

All parts used for the loom are metric. To facilitate the assembly, we have included two wrenches (10 mm for M6, 13 mm for M8), a socket-head screw wrench and a pz2 cross head screwdriver (not a Phillips head!).

List of parts

In box A:

- assembled middle part
- foot rail
- back beam

In box B:

- lower reed holder
- upper reed holder
- cloth beam
- warp beam
- breast beam
- shelf bottom
- reed (attached to the lams in Box A)
- 2 apron bars
- 2 cross sticks
- 16 warp sticks
- 400 heddles, length: 39 cm (Only with a Spring 110 cm; the other hedless are in box C)

In box C:

1. back beam and foot rail (attached to the middle part in box A) 10 treadles
2. 2 beater supports (L=R)
3. 2 floating arms (L=R)
4. brake handle
5. 2 base sides (L+R)
6. 2 middle side pieces (L+R)
7. 2 top side pieces (L=R)
8. 2 warp beam supports (L+R)
9. locking pin
10. brake disc
11. cloth beam lever
12. beater handle

Not shown on the picture:

- hardware bags 1, 2, 3, 4, 5 and an extra bag with hardware for spare.
- 60 long and 60 short tie-up cords for the treadles.
- 8 x 100 Texsolv heddles 39 cm.

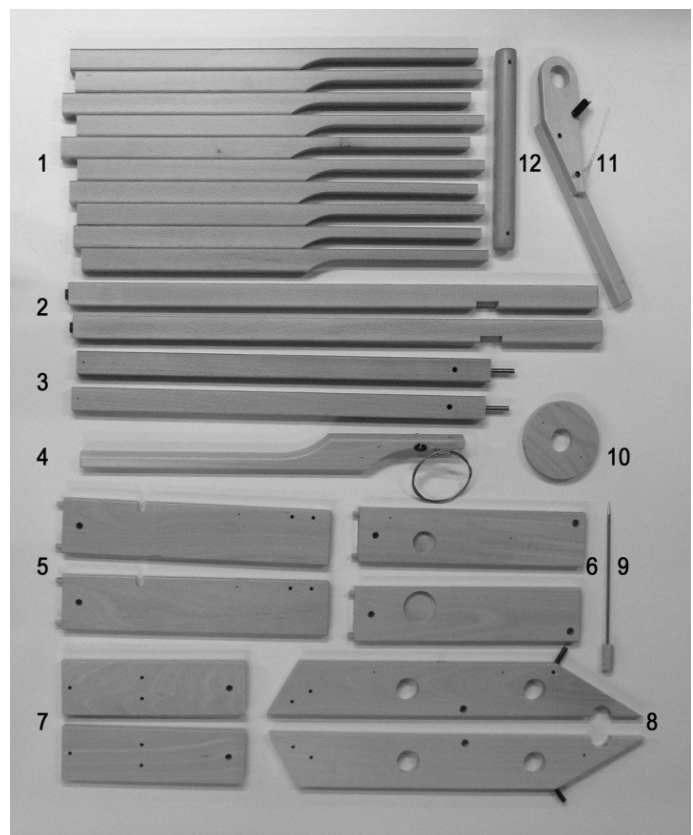

Assembly of the middle section of the loom

Place the already assembled middle part of the loom with its black buffers on the floor. The top side pieces are temporary attachments to keep parts in place and will be replaced during assembly.

Open hardware bag 1:

- a pz2 cross head screwdriver
- wrenches 10 en 13 mm
- socket-head screw wrench
- 2 buffers
- 2 screws 4 x 25 mm
- 4 threaded ends M6 with a socket and barrel nut
- 6 screws 5 x 50 mm
- bracket
- 2 carriage bolts M6 x 100 mm with washer and wingnut
- 2 screw eyes

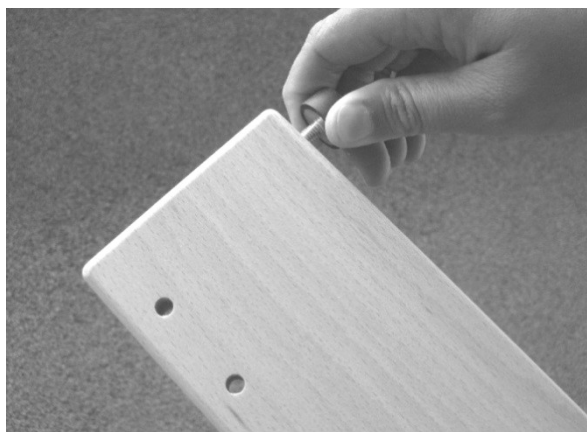

Screw the buffers onto the bottom side of both base side pieces.

Mount the base and the middle side pieces onto the middle part: These rails are marked A, B, C and D, which indicates where they are to be mounted onto the middle part.

Unscrew the barrel nuts from four of the threaded ends, but leave the socket-head nuts on. Insert these threaded ends from the back side through the holes in the middle part, where the side pieces have to be assembled.



Insert the barrel nuts into the holes of the side pieces.
The barrel nuts have to face the inside of the loom.

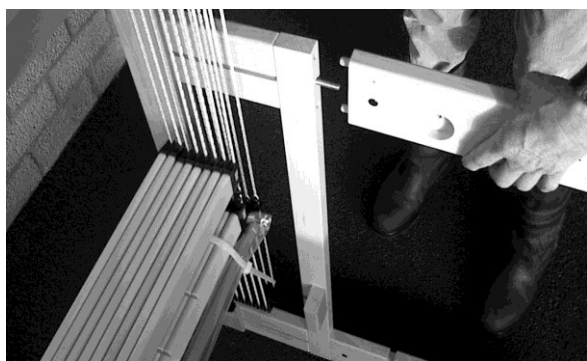

Fasten the side parts with the socket-head screw wrench.

On top of the loom there are two temporary side pieces, which need to be replaced by the regular side pieces.



It is important that the axles with rollers stay between the front and back rail. This means the front rail needs to be pushed backwards while replacing the side pieces. Make sure you replace the side pieces one by one!

Remove the two screws that hold the front rail.



Unscrew the socket-head nut and remove the side piece. If the threaded end remained in the barrel, take it out and take the barrel nut out too.

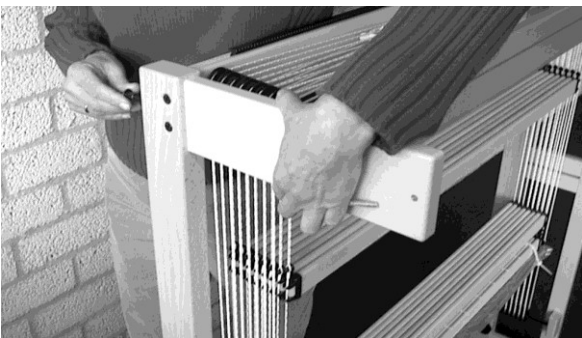

Insert the barrel nut into the new top side piece and assemble it in the reversed sequence, the barrel nut facing the inside.

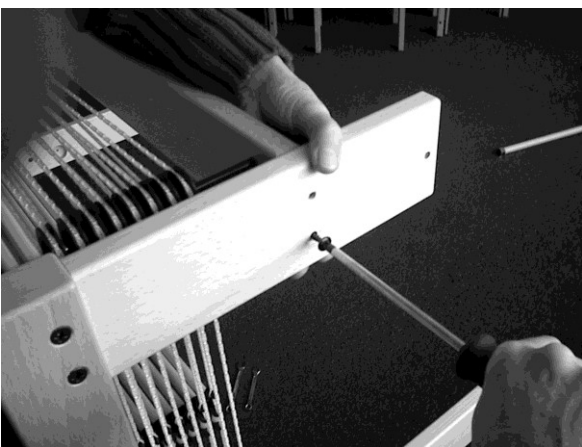

Screw the side piece to the front rail.

It is important to find the thread that is cut in the hole the first time: Lift the front rail and find its hole with the tip of the screw. Now turn the screw anti clock wise while giving some pressure. You will feel and hear when the screw falls in the original thread and you can screw it in, which should easily.

Repeat the procedure at the other side of the loom.



Slip the shelf bottom into the slot of the front rail. You may need to loosen the screws at the side pieces one turn.



Place the front rail of the shelf. Make sure the shelf bottom slides into the groove.



Fasten the shelf front to the top side pieces, using two of the 50 mm screws.

Assembly of the back section of the loom

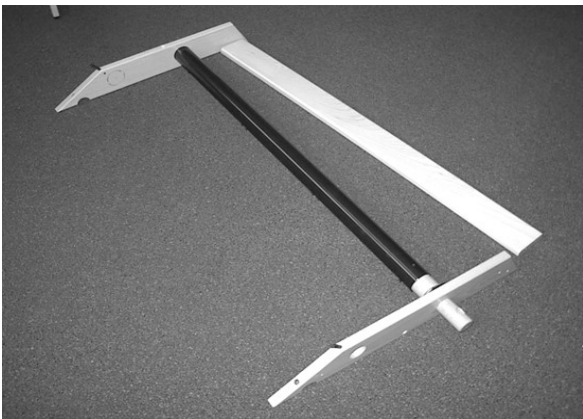

Take the warp beam, the back beam and the two warp beam supports and place them together as shown on the picture. Insert the shaft of the warp beam through the right support and slide the left support onto the other end of the warp beam.



Attach the supports to the back beam with the remaining 50 mm screws. At the right side you have to use these screws to attach the metal bracket.

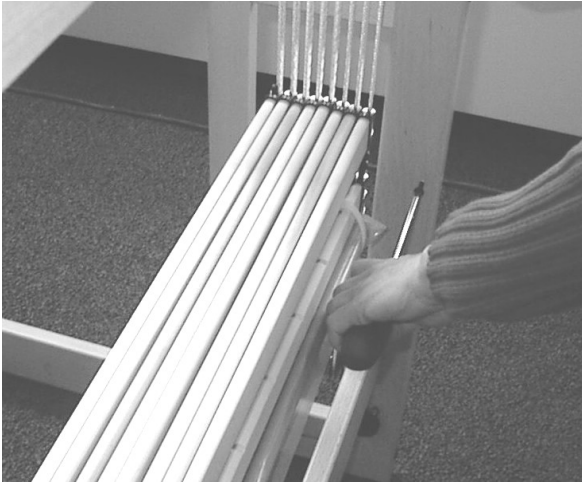

Screw the two 4 x 25 mm screws a few turns into the main uprights at the level of the holes in where the back part will be attached. The uprights are identical so you will find one pilot hole at the inside and one at the outside of the loom.



Place the back part in its location by inserting the polyurethane dowels into the holes at the rear of the loom.



Secure the polyurethane dowels by screwing the screws completely into the uprights, while holding the back part in a position that let the dowel in completely.



Take the two carriage bolts with washer and wing nut and secure the back part as shown on the picture.

When the loom is not in use, you can fold the back part of the loom after removing the wing nuts and washers again.



Screw the two screw eyes into the pilot holes at the backside of the warp beam supports. If you are used to leaving the lease sticks in the warp, attach them to these eyelets.

Assembly of the foot rail and treadles

Open hardware bag 2:

- 80 screws 4 x 17 mm
- 4 screws 5 x 50 mm
- 6 screws 6 x 70 mm
- 5 axles Ø6 x 122 mm
- 5 nylon spacer bushings
- 6 axle support blocks



Screw the small screws into eight holes of each treadle, so far that the screw heads protrude approximately 5 mm (3/16") from the wood. The thread of the screws should just disappear into the wood. Use the eight holes closest to the end of the treadle; the other four holes are to be used for an extension to twelve shafts.

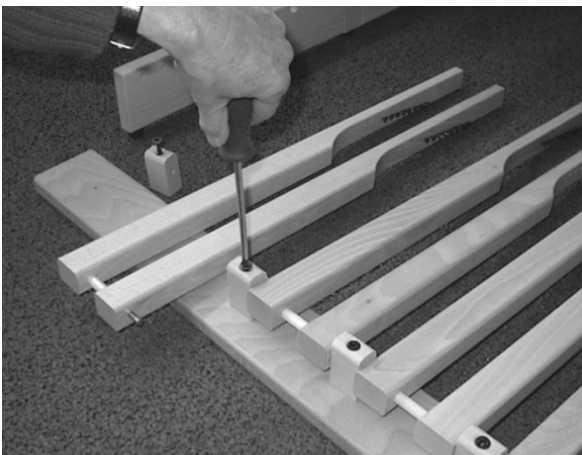

Place the foot rail upside down (pilot holes up) on the floor in front of the loom.

Assemble the treadles onto the foot rail. The screw heads on the treadles should point to the right.

Slide two treadles with a nylon bushing in between on each axle. Use the axle suspension blocks and the big screws to assemble these pairs of treadles to the foot rail. On each side, one pilot hole on the foot rail should not be used, unless you are assembling four more treadles of an extension to twelve shafts.

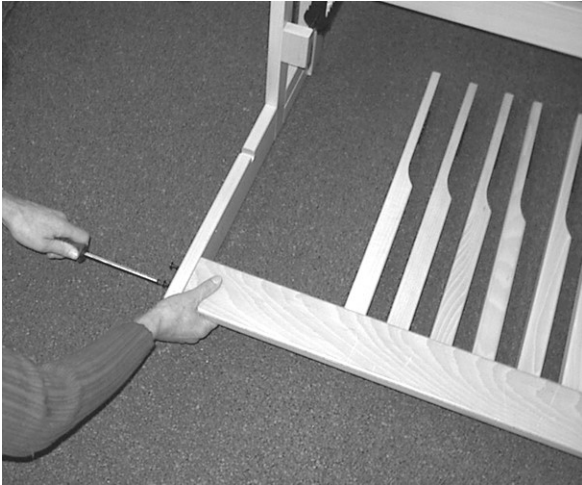

Turn the foot rail right side up again around the axles of the treadles, while the treadles stay on the floor and connect it with the four remaining screws to the base side pieces.

Mounting the floating arms

Open hardware bag 3:

- 2 carriage bolts M8 x 60 mm with big washer, bushing, small washer and cap nut
- 7 screws 4 x 17 mm
- 2 spring with a piece of Texsolv cord
- 2 short Texsolv cords
- 1 ratchet for the cloth beam
- 1 screw 4,5 x 20 mm round head
- 8 beam cords.

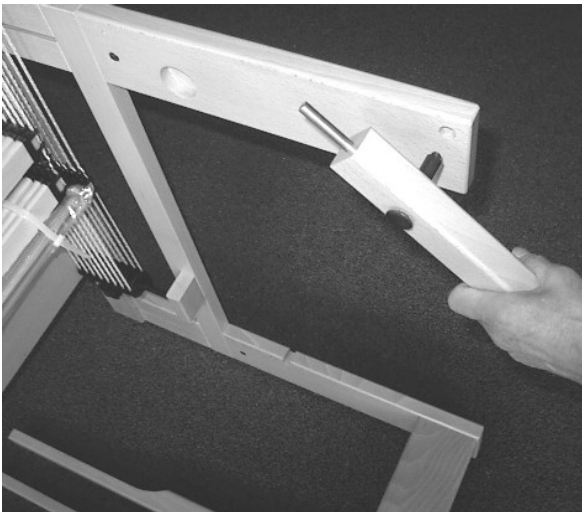

Take the wooden posts, recognizable for the steel rod at the end. These floating arms will hold the moving breast beam.

Tap the carriage bolts into the holes.

Slide the large washer and spacer bushing, over the carriage bolt and attach the floating arms at the inside of the middle side pieces of the loom.

Use the small washers and cap nuts to finish the assembly by strongly tightening the cap nuts.



Screw four of the small screws into the pilot holes at both sides at the bottom of the floating arms and a small screw at the inside of the base side pieces. The heads of these six screws have to protrude about 5 mm (3/16").

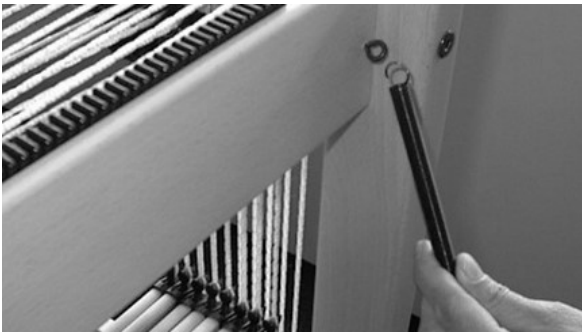

Hook on the springs to the screw eyes on the back at the top of the middle part.

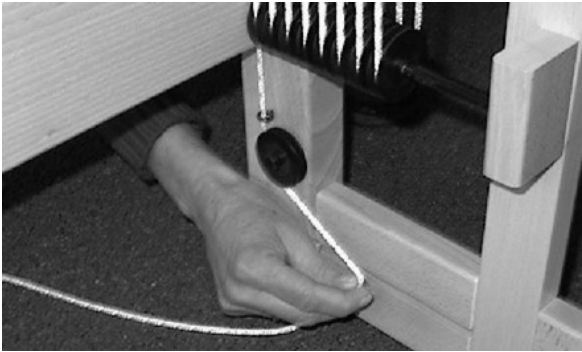

Bring the attached cords down through the screw eyes at the bottom of the main upright and lead them along the roller.

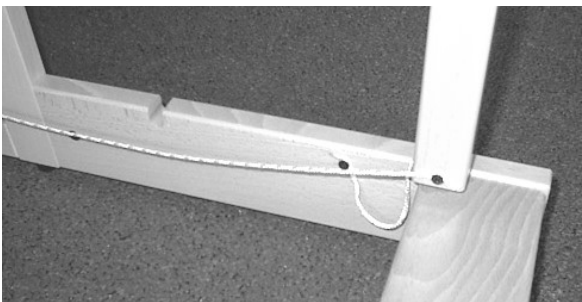

Attach the free ends of these cords onto the screw heads at the inside of the floating arms. Use the short Texsolv cords to connect the screw heads at the outside of the floating arms and the inside of the base side pieces.

Installing the cloth beam



Slide the cloth beam lever onto the cloth beam and make sure that the ratchet is on the right side of the ratchet wheel.



Install the cloth beam with the wooden end into the hole of the right middle side piece and the metal end into the circular groove of the left side piece. You will need to push the side pieces apart to install the cloth beam in between.

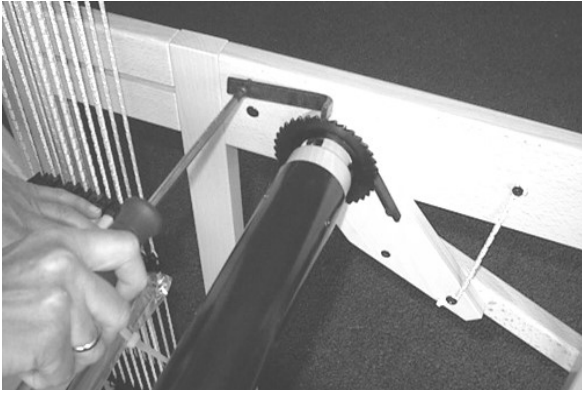

Attach the cord of the lever with the remaining 4 x 17 mm screw onto the side piece.

Use the 4.5 x 20 mm screw to attach the ratchet onto the side piece. The ratchet has to turn freely, so don't fasten it too much.

If the ratchet on the lever is falling to the wrong side while advancing the cloth beam you need to shorten the cord one or two cord loops

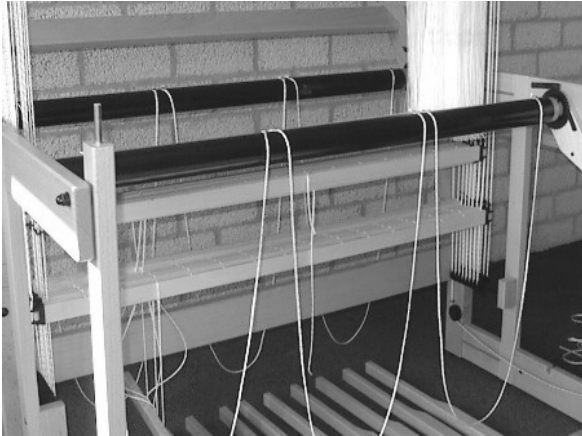

Attach the beam cords onto the screw heads of the cloth beam and the warp beam.

Assembly of the beater

Open hard ware bag 4:

- 2 beater hinges
- 2 buffers
- 2 bolts M6 x 70 mm with washer and barrel nut
- 2 lag bolts 8 x 90 mm
- 2 spacer bushings 33 mm
- 4 washers
- 2 carriage bolts M6 x 80 mm with washer and wing nut.
- 1 locking pin
- 3 strips of thin cardboard



Remove the reed from its location between the lambs by taking away the tie straps. You can cut them but you can also lift the small ratchet inside with the tip of a knife so they can be used again.



Insert the locking pin into the hole in the top rail and through the marked cord loops. Now the shaft bars and lams are fixed in their neutral position.



Turn the beater hinges into the bottom of the uprights.

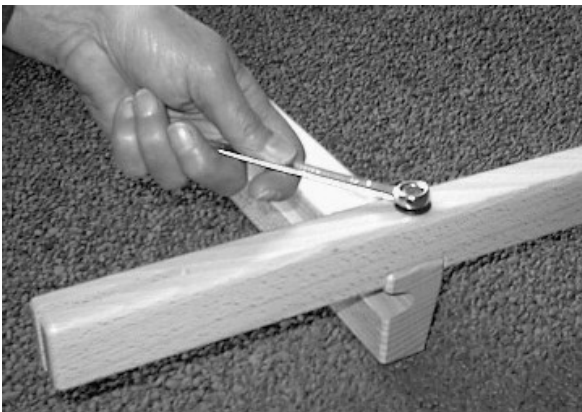

Connect the lower reed holder (the one with the slanted side) to the uprights: Place the barrel nut into the hole on the end of the lower reed tray. Slide the upright with the notch over the lower reed tray. Place the bolt with washer in the hole and screw it into the barrel nut. Tighten the bolt and, in the same way, assemble the other upright on the other side of the reed holder.



Screw the buffers into the holes at the sides of the loom, see picture. If your loom has twelve shafts you need to use the other hole you see on the picture.



Place the assembly of uprights and lower reed tray into the loom. First guide one hinge along the side rail and then the other one. Put the hinges into the openings in the base side pieces.



Slide a washer over the lag bolts and then put them through the holes in the upper reed holder.

Next slide another washer and a spacer bushing over the lag bolts.

Hold the handle with the holes over the points of the lag bolts and then tighten the bolts so far that the spacer bushings are tightened slightly into the handle.



Assemble the upper reed holder with carriage bolts, washers and wing nuts. Insure that the washers rest under the wing nuts and not between upright and reed holder.

Fasten the wing nuts, while you keep the top reed holder parallel to the lower one. You can also do this by placing a reed in between. After each tap on the bolt head you turn the wing nut tight again until the square part of the head is completely pressed into the wood.

Move the beater backwards, so it rests against the buffers at the sides of the loom.

Now we will check if the beater is even and make a correction if necessary. First check if the hinges protrude the same distance from the bottom of the uprights. Take the beater by its handle and pull it towards you, one or two inches.

If the beater is even, both uprights will leave the buffers at the same moment and also touch the buffers at the same time when you let the beater go back and rest against them.

If this is not the case, the beater is not even and you will correct that with the small cardboard strips from the hardware bag.

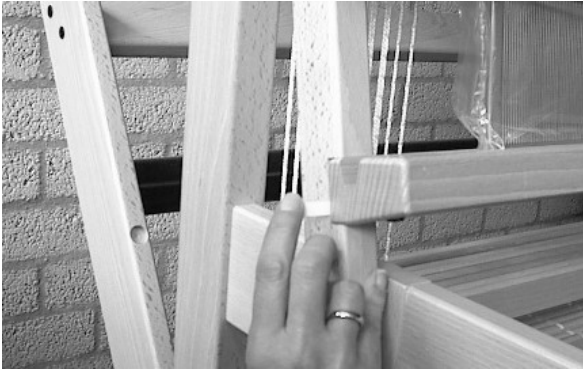

The upright that leaves the buffer last when you pull the beater, is the one that needs one or more cardboard strips in its slit connection with the lower reed holder.

Unscrew the M6 bolt several turns, so that some play is created in this connection.

Slide a cardboard strip completely into the slit at the bottom and fasten the M6 bolt again.

Check if the beater is even now, and if not, use one or two more strips in the slit.

Assembly of the brake of the warp beam

Open hardware bag 5:

- 1 wooden dowel
- 2 screws 4 x 35 mm
- 1 carriage bolt M8 x 55 mm with 4 washers, bushing, 1 washer and a cap nut
- 1 threaded hook with a knurled nut
- 1 lag bolt 6 x 30 mm.
- 1 ratchet
- 1 screw 4,5 x 20mm
- 1 spring

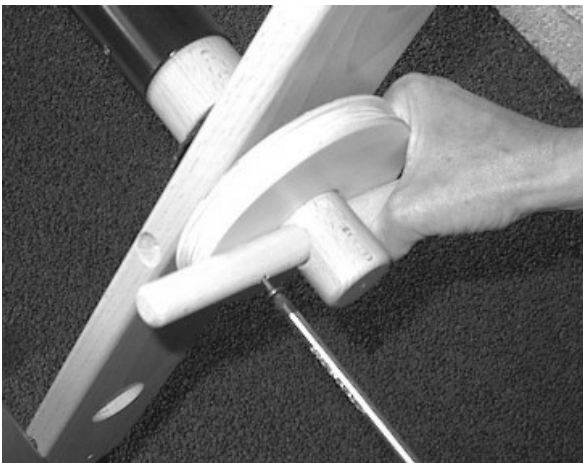

Slide the brake disc over the wooden end of the warp beam and fasten it with the dowel and the two screws 4 x 35 mm.



Screw the lag bolt 6 x 30 mm into the pilot hole in the warp beam support, just so far that the thread of the bolt disappears into the wood.

Hang the spring onto the head of this lag bolt.



Tap the carriage bolt into the hole of the lever from the side that is curved and slip on four washers and the bushing.

Hook the spring onto the hook of the lever. Insert the lever with the carriage bolt and the bushing through the hole in the warp beam support. Complete this assembly with the last washer and by tightening the cap nut.



Attach the threaded hook and the knurled nut to the bracket as shown on the picture.

Guide the cable two turns around the brake disc and insure that the turns don't cross each other. Slip the eye of the cable onto the threaded hook, while you lift the lever.

With the knurled nut you can adjust the position of the brake lever, which should be about horizontal. Lift the lever with your knee to release the tension while you turn the knurled nut.



Screw the pawl into the hole above the ratchet wheel. Then again a little loose, so that the pawl can rotate. Put the pawl out of the ratchet wheel during the weaving and use of the brake like the picture shows. When putting a warp on, it is convenient to use the ratchet wheel and release or take off the brake cable.

Tying the treadles

In hardware bag 6 you will find shorter and longer tie-up cords for the treadles.

The tie-up cords are pre-cut in the correct lengths. The longer cords should be used to connect the upper lams to the treadles, the shorter cords should be used to tie the lower lams.

If a shaft is tied to a treadle by means of its upper lam, the treadle will pull the shaft down, so the tie-ups to the upper lams correspond to the X marks of a weaving draft. If a lower lam is tied to a treadle, the treadle will lift its shaft up, so these tie-ups correspond to the O marks.

Tying-up a countermarch loom, using a weaving draft for a singular tie-up, that only shows X marks, the blank squares are the tie-ups to the lower lams and the other way around, if the weaving draft is showing only O marks, the blank squares are the tie-ups to the upper lams.

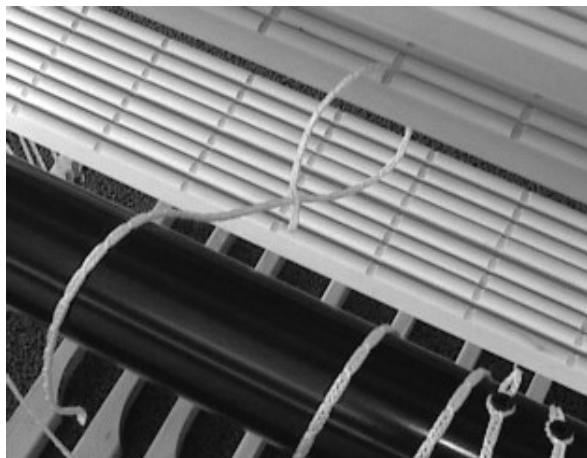

First make the tie-ups to the upper lams. Loop the cord around the lam and pass one end through the last loop in the other end. Tighten it after the cord is positioned in the groove in the lam, right above the treadle to be tied.

The tie-up cords of the upper lams have to pass the lower lams. As a rule these cords pass behind of the lower lam, associated with the same shaft. That will help you to avoid the error of tying-up both the lams of a shaft to the same treadle: In front of each cord passing the lower lams, the groove in the lower lam should not be used for a tie-up.

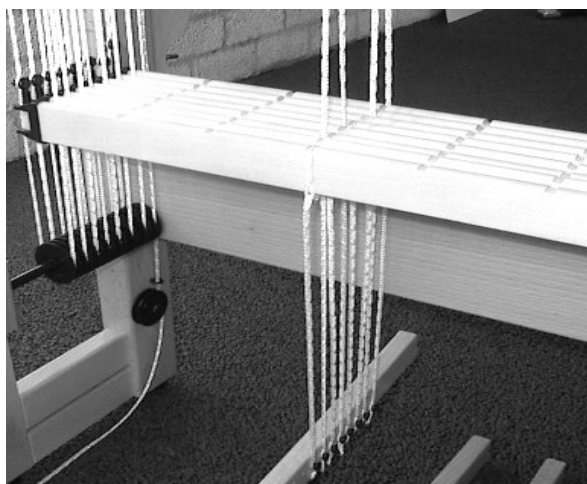

The cords should be tied to the screw heads on a treadle in a sequence, corresponding to the shafts.

Tie the lower lams to the treadles: Each groove in the lower lams that is not past behind by a cord should be tied to the screw head on the treadle right below.

When all the tie-ups are made, check if all the cords are about the same tightness. If there are big differences, you probably misjudged which loop was the last loop of one or more cords. Another cause may be that one or more lam is not fixed to the right level (see next subject).

All shafts will be tied to all treadles used, some to rise and some to fall. If you want to change the tie-up, only unhook the cords from the screw heads and slide the cord over the lam to the groove where you need it. On some lams you will need to add more cords, on some lams they will be left over. You may leave that cords looped over the lams at the sides.

Adjusting the shaft bars and lams

Shafts and lams are already adjusted of the correct height. They may need a correction after some time.

You can check the correct level after putting the locking pin into the hole at the top of the castle and through the marked loops of the parallel cords. Now the whole system is locked in its neutral position. If the marks on the cords fade, mark them again with a felt pen.

The adjustment of shaft bars and lams can be done in steps of 12 mm, by clicking them into next loop of the cord. For finer adjustment you have to turn the white nut that adjusts the hook, attached to the cord.

The correct height of shafts and lams is easy to understand and therefore easy to keep in mind: In their neutral position the shafts have to be fixed at the height that the warp on the loom passes through the middle of the heddle eyes. The distance between the shaft bars should be far enough to keep the heddles stretched, but remain moveable along the bars.

The lams should be at such a height, that their tie-ups to the treadles keep the treadles in an angle whereby the row of screw heads is horizontal.

The difference in height of the upper and lower lam has to correspond to the difference in length of the tie-up cords to the treadles.

Tips and tricks for using the loom

Adding or removing heddles



Cut with sharp scissors at the ends of the bundle of heddles the loops with which the heddles are connected to each other. Only remove the straps from the bundles after the shaft bars have been inserted, otherwise a big mess will occur



If you need to add heddles to a shaft, pull the hook that connects the upper shaft bar to the cord, out of its cord loop. Slip over a bundle of heddles and push the hook back into the same loop again. Repeat this with the lower shaft bar, but untie the bundle before you attach the lower bar into the cord again.

Naturally, reverse the steps to remove heddles and don't forget to tie them together at four places, right after you release the tension by unhooking the lower shaft bar.

If your warp doesn't need the whole weaving width of the loom, you can leave the heddles that you don't use on the shafts at the sides.

Clicking the hook out or into the cord is easier after you release its tension by taking the cord out of one or two rollers at the castle top. By releasing the tension this way, the whole cord changes place a bit and you have to pay attention to use the same loop, pushing in the hook again. The potential error shows up when you replace the cord onto the rollers: The shaft bar differs in level. To avoid errors you could mark the loop with a felt pen.

The cross sticks

If you are used to leaving the cross sticks in your warp while weaving, the cross sticks should be tied to the screw eyes at the back of the warp beam supports. By doing this, you will avoid the lease sticks following the warp toward the shafts, when you advance the fabric.

Cross sticks in between the back beam and shafts reduce the usable depth of your loom.

The raddle

The plastic raddle strip on top of the castle has 2 dents to 1 cm (5 dents to the inch).

Because the raddle is built up from 10 cm strips with half an opening at each end, you will lack one opening for a loom wide warp. In that situation you have to add some more warp ends into the openings at the outside.

The middle of the raddle is marked as a guide for starting to thread the warp.

Threading through

The warp always should be threaded through the heddles of at least four shafts. Using only two shafts for a tabby, you will overload the shaft bars and lams. Lock the shafts, not in use, in their neutral position.

Tying the warp to the beams

The apron rods are marked at the spots where the cords have to be attached. The diagram shows the usual loop to do this.

After the warp is threaded through the heddles and the reed, the warp ends have to be tied to the apron rod of the cloth beam. For this job the breast beam should be blocked, otherwise it is impossible to get an even tension on all warp ends: Every time you tighten a bundle of threads, the breast will move and release all the other warp ends. When you take the spring cords off the floating arms, the short cords you installed to connect the arms to the loom will block the breast beam.

Adjusting the warp tension

Release the warp tension after you have tied the warp to the apron rod of the cloth beam, by lifting the brake lever of the warp beam.

By attaching the spring cords to the screw heads at the floating arms you can adjust the tension on the warp: The tighter you tension the cord, the more tension you will get on the warp. Be sure to adjust about the same tension on both sides.

The warp tension should always be judged with the floating arms in the vertical position. The arms move to the front when you advance the cloth beam, and move backwards when you lift the brake lever.

To advance the fabric while weaving, first lift the brake lever. Due to the springs, the breast beam moving toward to you, will pull some warp from the warp beam. Advancing the fabric using the cloth beam lever, you will bring the floating arms back in their vertical position. Now the moving breast beam demonstrates its other feature: The warp tension is automatically the same as it was before you advanced the fabric.

If you advance the fabric too far, first you have to release the warp tension by lifting the brake lever, than you can take both the ratchets out of the ratchet wheel of the cloth beam. Turn the cloth beam back and put in the ratchets again. Now stand at the side of the loom and lift the brake lever turning the warp beam backwards.

Adjusting the height of the beater

The beater hinges are screwed with their threaded ends into the bottom of the beater supports. This construction allows you to adjust the beater level: Turn the beater hinges in- or outwards. The beater height should be adjusted, so that the lower shed just touches the lower beater bar. So if you use a smaller shuttle for fine yarn, you may adjust the beater a bit higher, because a big shed is not needed.

Always be sure that the beater has the same height at both sides. You can check this by making a shed and watching the lower warp ends touch the lower beater bar.

Folding the back section

To fold up the back section of your Spring, you have to remove the wing nuts and washers at the bottom of the warp beam supports.

If there is a warp on the loom, you can keep it folded by the tension of the warp. In the other case you have to tie the back section to the main upright of the loom.

Folded, you can move the Spring through most doors.

Maintenance

Your Spring loom is easy to maintain. One month after you assembled it, retighten screws, bolts and nuts of the construction, including the part that was already assembled. Thereafter, check all bolts, screws and nuts once a year.

Troubleshooting

General checks for proper functioning

- Check the level of the shafts, lams and treadles, while the parallel cords are locked by the pin in their marked loops.
- Check that the parallel cords run through the grooves in the black plastic ends of the lams and shaft bars.
- Check that both the spring cords run in the grooves of their rollers.
- Check that the washers are underneath the wing nuts, where the top beater bar is attached to the supports. If the washer is located in between the beater bar and the support, it will make the beater unstable and the wing nut will damage the wood.

The shed is poor or hard to make

May be caused by:

- The treadles are tied too high or too low.
- The lams aren't adjusted at the right level.
- The beater is adjusted too high.
- The lease sticks are in the warp between the shafts and the back beam.
- The fabric should be advanced.
- The tie-up cords to the treadles cross each other.

A treadle cannot be pushed down

May be caused by:

- The locking pin is still in the parallel cords.
- An error in tying-up the treadle: The treadle is tied-up to both the upper and lower lam of the same shaft.

During tying the warp to the apron bar of the cloth beam, the tension on the warp stays irregular

May be caused by:

- The spring cords have not been unhooked from the screw eyes of the floating arms.
- One of the extenders is not fixed onto its support.
- The brake cable doesn't run properly over the brake disc or the cable needs to be tightened.
- One of the short cords doesn't block the floating arm.

The warp wouldn't come off from the warp beam.

May be caused by:

- The brake lever has to be lifted further.
- The brake lever is adjusted too high: release the cable a bit.
- While weaving with a very low warp tension, the warp wouldn't pass the cross sticks: Take them out. If that doesn't solve the problem, you have to beam the warp beam by hand, while lifting the brake lever.

The cloth is slanted

May be caused by:

- One of the wing nuts that hold the warp beam supports came loose.
- The beater is not adjusted on the same level at both sides.
- The tension of the springs is not the same on both sides.
- One of the spring cords has slipped of the roller.

The cloth cannot be advanced

May be caused by:

- One of the ratchets of the cloth beam is not in the ratchet wheel.
- The apron bar of the cloth beam is caught on one of the floating arms.