

# Delta

## Instructions for assembly



The parallel countermark system.....	1
Assembly tips and information.....	3
Assembly of the Delta.....	5
Maintenance.....	28





## The parallel countermark system

In a countermark loom, every shaft is actively involved in each shed: Each shaft is either lifted or pulled down by each treadle.

Uneven sheds, for example a satin weave shed, where four shafts are lifted and one is pulled down, open cleanly every time. The warp ends on the fifth shaft do not tend to ride up as they often do with jack looms.

When the shed is made, the same tension is applied to the raised warp threads as to the lowered ones, resulting in the best shed in relation to the increase of the warp tension.

## The traditional countermark

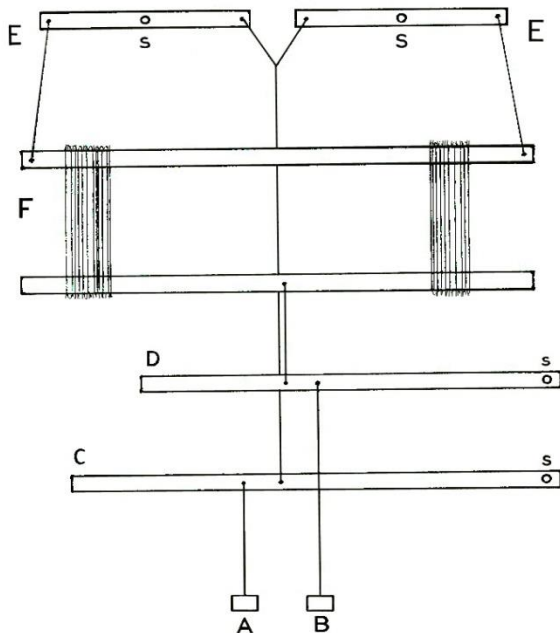

Look at the diagram to help you understand how a countermark loom works. The points marked S are the pivoting points for the lams C and D and the jacks E.

You will see that beneath each shaft, there are two lams associated with it. One of those lams is directly connected to the shaft and moves in the same direction as it does: when this lam is pulled down, the shaft moves down. When the other lam is pulled down, the shaft rises.

## Parallel countermark

See the next picture; each shaft is attached to a cord, which goes over all six pulleys. The ends of the cord are joined so the cord forms a continuous loop. When treadle A is pressed down, the lower lam C, attached to the outside

part of the cord, moves downward, pulling the shaft F up. When treadle B is pressed down, the upper lam D attached to the inside part of the cord, goes down, pulling the shaft with it.

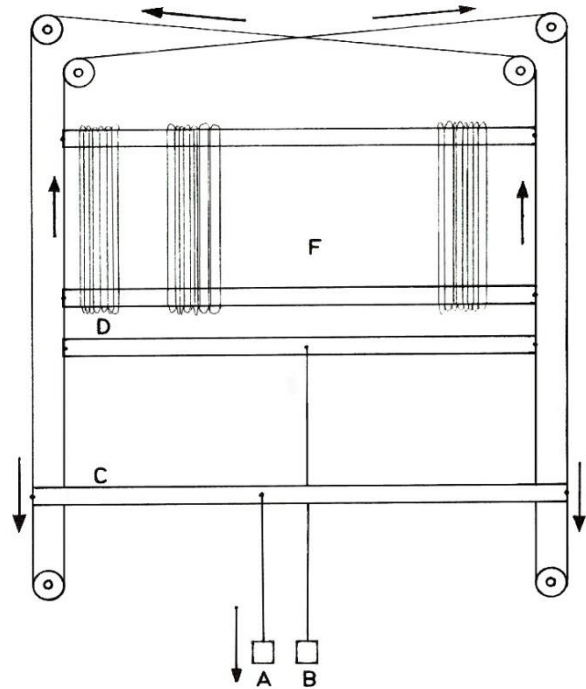

Compared to the traditional countermark, the parallel countermark has five nice features:

1. In contrast to the traditional countermark, the lams of the parallel countermark stay horizontal, while moving the same distance as the shafts. This means that the travel of all treadles is the same, not dependant on their location in the width of the loom.
2. The parallel countermark system is more compactly constructed, because the action space the lams need is less than pivoting lams and the rollers at the top take less space than jacks.
3. Shaft bars and lams cannot slant. Their ends are fixed to the cord and when the cord moves, all parts of the cord have to move the same distance.
4. There is no tie-up to the middle of the lower shaft bars, so the heddles can be moved freely over the full length of the shaft.
5. There are no cords, connecting the lams to jacks, running through the middle of the warp

Because each treadle is tied to one of the lams of each shaft, twice as many tie-ups per treadle must be made, on the average, compared to looms with another system.

Before the advent of Texsolv cord, the time required to tie up a countermark loom was

daunting. Once the ties were made, there were still problems as knots slipped or had to be untied to adjust the cords. The Texsolv cords neither stretch nor require knots. The Texsolv tie-up cords are attached to the lams and can be simply hooked onto the treadles. Changing the tie-up is easy and fast.

To improve the countermarch shed, to offer the best shed a shaft action system can provide, Louët invented an action system for another part of the loom that holds the warp:

### The moving breast beam, controlling the warp tension

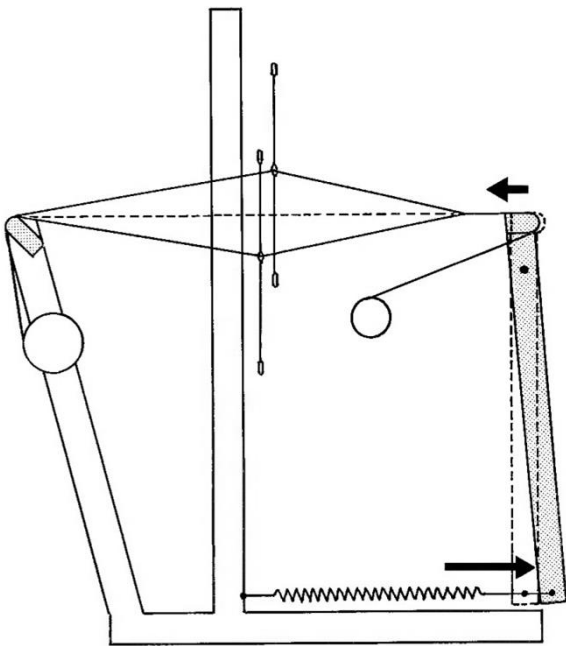

The moving breast beam allows the shafts to move more easily in their opposite directions. Looking at the diagram that shows the loom from the side, you will see that a shed is giving the warp a kind of parallelogram shape. Imagine, the warp is made of inelastic material, like metal wire, you will understand that making a shed is only possible if the distance between breast beam and back beam becomes smaller. When this distance is fixed, as it is on other looms, the shed depends completely on the elasticity of the warp. When the shed becomes wider, the tension on the yarns increases (enormously, in case of a less elastic warp). That causes heavy treadling and may damage the warp. The moving breast beam is held by springs, adjustable to give your warp the tension needed for your project. Besides improvement of the shed and protection of the warp, the springs guarantee exactly the same warp

tension each time you have to advance the fabric.

**The Texsolv** system, cord and heddles is a Swedish product, crocheted out of polyester yarn.

Cotton heddles have the advantage of being silent in use. Metal heddles, flat or wire, have the advantage of having open eyes. Texsolv heddles combine these features. A bundle of Texsolv heddles is a continuous line of 100 heddles folded into a zigzag. Each bundle is fastened in four places. These ties make it easy to pass the shaft bars through the upper and lower loop of the heddles. Do not remove the ties from the bundles, until the heddles have been slipped onto the shaft bars or the loops of the bundles are inserted by sticks, to protect the heddles from becoming entangled.

If you need to remove heddles from a shaft, first tie them as they were originally. Use a pair of sharp scissors to cut the heddles apart.



Texsolv cord consists of two cords, which are connected every 12 mm, forming loops in between. If needed, the cord should be cut between two loops. To prevent unraveling, the ends should be singed. Be careful not to overdo the melting and be aware that melted polyester is very hot and will burn the skin.

By mentioning the first or last loop in these instructions, the loop is meant, next to the one where the cord is cut, because when that loop remains after cutting, it has no strength and should not be used.

## **Assembly tips and information**

### **Barrel nuts**

For the assembly of the looms, we use barrel nuts and bolts or threaded rods to connect two parts. These cylinder shaped nuts have a slot on one of the flat sides. Always insert the barrel nut into the wooden part, so that the slot in the barrel nut is visible. The slot shows the direction of the threaded hole in the nut. With a flat screwdriver you can turn the barrel nut so that it is positioned properly to catch the bolt. If you have a problem inserting the bolt into the barrel nut, try turning the barrel nut 180 degrees. This usually helps.

### **Carriage bolts**

In other locations, we use carriage bolt to assemble wooden parts. These bolts have a square enlargement (neck) under the bolt head. When you tighten the nut on the bolt, this square neck locks into the wood to prevent the bolt from turning. In some instances, you will notice, that the bolt is just a little too short for assembly with the washer and nut. We advise you to put the nut on the bolt without the washer, and then tighten the nut sufficiently, so that the square neck pulls into the wood. At this stage, unscrew the nut, install the washer and then replace and secure the nut again, tightly. Alternatively, you can carefully tap against the bolt head with a hammer, until the bolt head is secured into the wood.

### **Washers and spacers**

For the proper operation of the loom, it is very important that you follow the correct assembly sequence of the bolts, washers and spacers. Please carefully follow the instructions.

To help you, we have assembled all the washers and spacers in the hardware bags in the right sequence.

### **Wood screws**

Where wood screws are used, we have pre-drilled holes in the wood. The screws will cut their own thread into these holes. Please note however, that the screws are very sharp, and will cut into the full wood outside the pre-drilled holes, if you miss the pre-drilled hole during assembly. However if this happens, you will notice that after a couple of turns, it becomes very hard to turn the screw. There is even a chance that the screw will twist off. Moreover, the parts will be assembled in the wrong location.

If you have to assemble and disassemble the loom several times, make sure that the wood screw turns in the same thread again which was cut the first time. If you do not follow this instruction, the hole in the wood will become too large for the screw. To find this screw thread, turn the screw anti clock wise, until you "feel" the screw "drop" into the threaded part in the wood.

### **Tools**

All parts used for the loom are metric. To facilitate the assembly, we have included two wrenches (10 mm for M6, 13 mm for M8) and a pz2 cross head screwdriver (not a Phillips head).

## Assembly of the Delta



It will take you approximately 5 hours to complete the assembly of the Delta.

The Delta is packed in three boxes and a fourth box inside of box A.



Lay down box A horizontally on the floor and open the box at both ends. Push the castle section out of the box so that you can cut the straps of the fourth box. Put this aside, you will need the contents in the second part of the assembly.

remove the castle section completely out of the box.



Find the following parts inside box B:

1		bag with a screwdriver and wrenches 10 and 13 mm
2		hardware bags 1, 2, 3, 4, 5 and a bag with some spare parts
3		crank for the warp beam
4		cloth beam lever
5		beater handle
6		2 extenders
7		left and right side piece
8		left and right base side
9		left and right warp beam support
10		2 floating arms
11		2 beater uprights



## Assembly of the frame

The parts of the frame show corresponding letters: A, B, C, etc., at places where they have to be assembled.

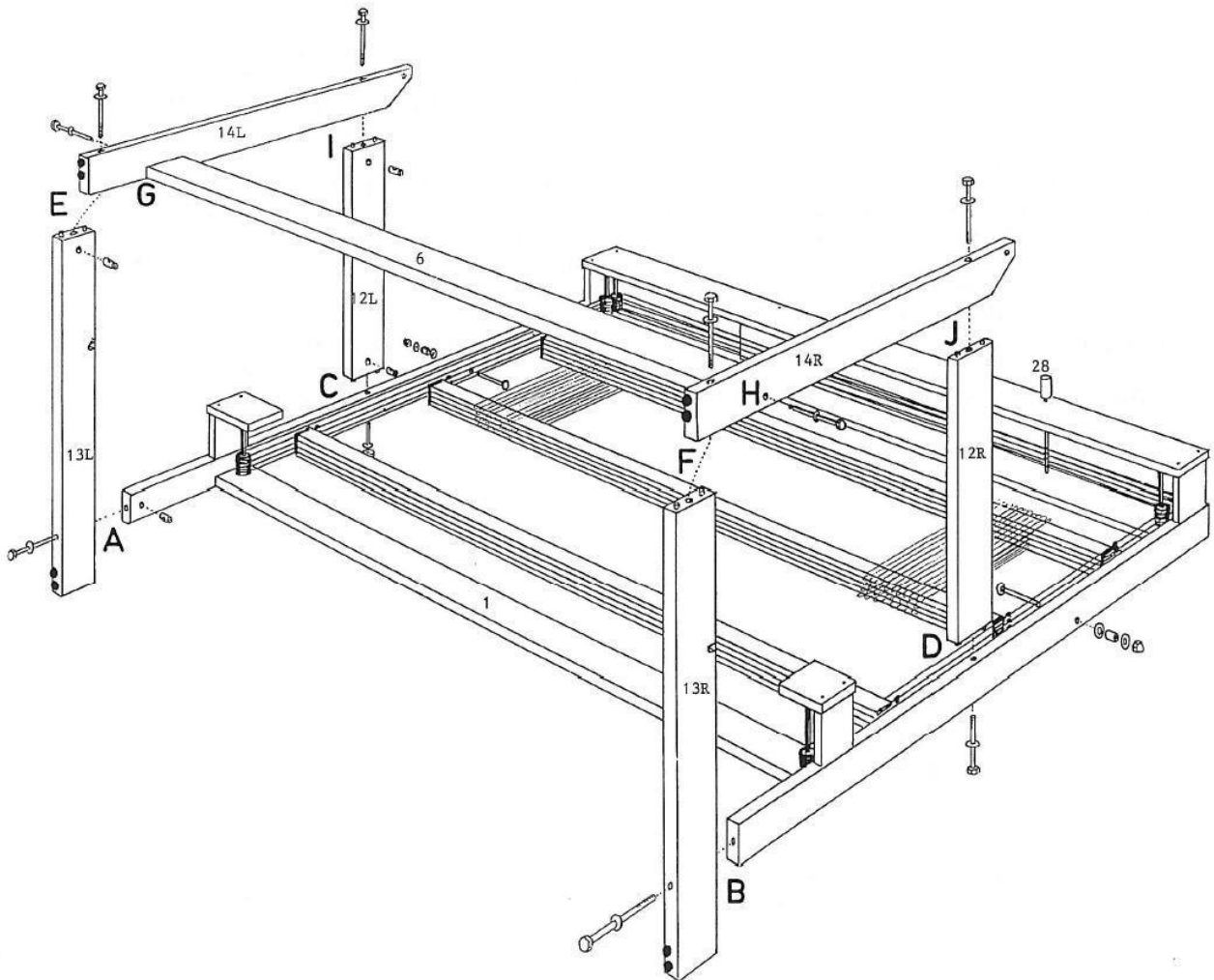

Open hardware bag 1:

- 6 bolts M8 x 130 mm with washer Ø8-25 mm and barrel nut M8
- 2 bolts M8 x 110 mm with washer Ø8-25 mm and barrel nut M8
- 2 bolts M8 x 70 mm with washer Ø8-25 mm and barrel nut M8
- 2 carriage bolts M8 x 65 mm with each 2 washers Ø8-25 mm, nylon bushing Ø8-12 x 20 mm and a star shaped knob M8
- 2 rollers
- 2 lag bolts Ø6 x 35 mm
- 2 screw eyes
- 4 rubber buffers
- 1 plastic buffer
- 1 screw 4 x 21 mm



Place the already assembled middle part of the loom with the backside on the floor and assemble the base side parts (connections A-A and B-B). Use 2 bolts M8 x 130 mm with washer and barrel nut.



Mount both side pieces onto the uprights of the middle part with 2 bolts M8 x 110 mm, washer and barrel nut (connections C-C and D-D).



Now the front uprights have to be mounted onto the side pieces of the loom with 4 bolts M8 x 130 mm, washer and barrel nut (connections E-E, F-F, I-I and J-J).

Open box C and find:

- Treadle rail.
- Upper reed holder.
- Breast beam with cloth protector.
- Clothe beam.
- Lower reed holder.
- Foot rail.
- Back beam.
- 2 Apron bars.
- 2 Cross sticks.
- 16 Warp sticks.



Assemble the foot rail (connections G-G and H-H): Place the foot rail at one side with its dowels into the holes of the upright. Now you can position the dowels into the holes at the other side after pushing the upright and the foot rail from each other.



Fasten the construction with the bolts M8 x 70 mm, washers and barrel nuts.



Screw the 4 rubber buffers into the holes at the bottom side and put the Delta on its feet.

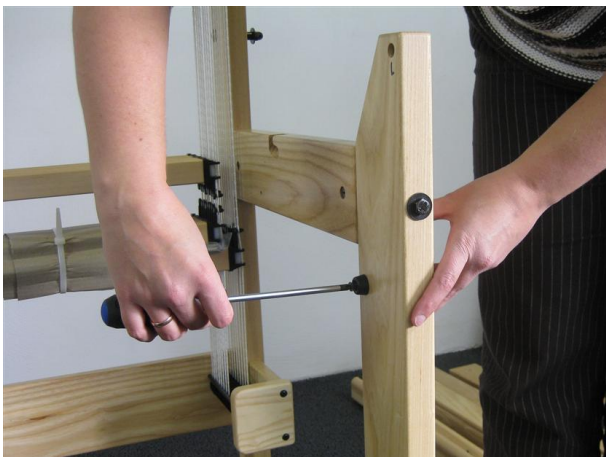

Attach the plastic buffer onto the inside of the right front upright with the screw 4 x 21 mm. This buffer will support the cloth beam lever.



Screw on each side a screw eye into the little hole near the connection of upright and base side part.  
Screw them so far that only the eyes protrude from the wood (the eye of the screw eyes "looking" in vertical direction).



The rollers have to be attached using the lag bolts. Fasten them and then unscrew them a little to allow the rollers to turn freely.



Two carriage bolts M8 x 65 mm with each two washers, a nylon bushing and a star shaped knob should now be assembled onto the side uprights of the loom. They will be used to connect the extenders, as you can see on the picture. These extenders will be assembled later on.

Insert the bolt from the inside through the hole in the upright, put on successively a washer, the bushing, the other washer and complete the assembly with the star shaped knob.

## Assembly of the warp beam part



Open hardware bag 2:

- 4 screws 5 x 40 mm
- 2 screws 4 x 30 mm
- 2 bolts M6 x 70 mm with washer and barrel nut
- 2 bolts M8 x 100 mm with a small washer, a metal bushing, a big washer and a barrel nut
- 2 screw eyes



Collect the brake disc and the warp beam. Slide the disc over the longer axle of the warp beam (connection Q-Q). Fasten the disc with the four screws 5 x 40 mm.

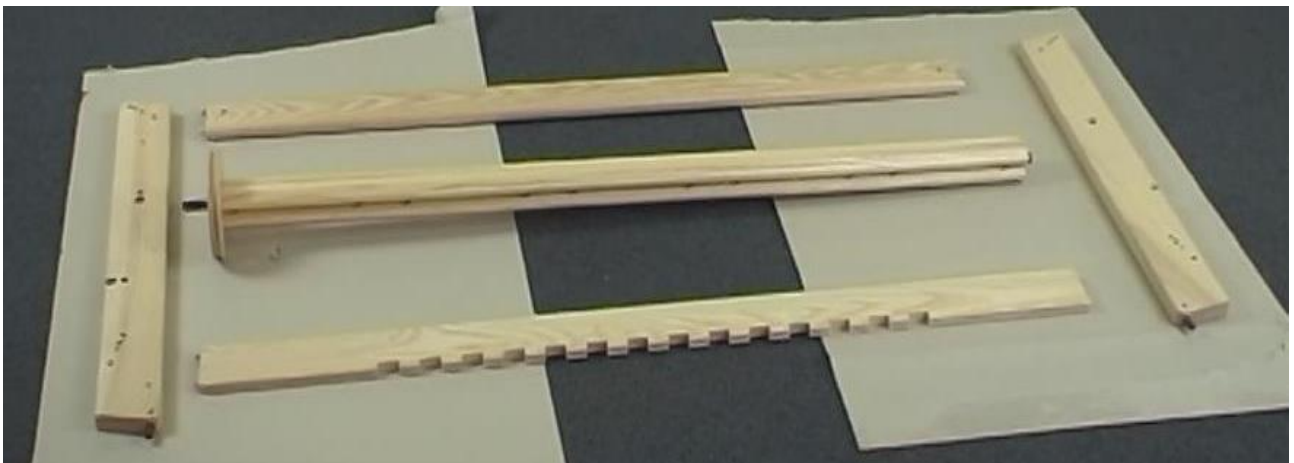

Collect the other parts needed for the warp beam section: The back beam, the treadle rail and the two warp beam supports. You will recognize them from their connection marks: O, P, M and N. These marks will help you to position the parts on the floor in the way they should be assembled. The notches in the treadle rail should face the outside.



Insert successively the treadle rail and the back beam with their dowels into the warp beam support (connection N-N and P-P).



Position the warp beam in combination with its other support and push this warp beam support onto the dowels of the treadle rail and the back beam (connections M-M and O-O).



Take the two extenders and the two bolts M8 x 100 mm with washers, bushing and a barrel nut.



Mount these three parts on both sides: the extender, the warp beam support and the back beam. The bushing should be inserted into the hole of the extender, so the extender can hinge in between the two washers, due to the bushing being a bit longer than the hole in the extender.

Do mind that the gap and the dowel in the extender are facing upwards when the warp beam section is in the position as showed on the picture.



Fix the connection of the treadle rail to the warp beam supports using the last two bolts with washer and barrel nut from the hardware bag. As you can see on the picture, the barrel nut has to be inserted from the bottom side in this position.



The two little screw eyes have to be screwed into the small holes, located close to the back beam. Screw them so far that only the eyes are protruding from the wood.

If you are used to leave your cross sticks in the warp during weaving, you have to attach the cross sticks to these screw eyes to prevent the sticks from passing the back beam when you advance the cloth. The two screws left will be used to attach the warp beam section to the loom.

### **Mounting the warp beam section onto the Delta and assembly of the treadles**

Open the box that was packed in box A and unpack the treadles and other parts: a hardware bag, heddles, tie-up cords for the treadles and the locking pin. Open the hardware bag:

- 5 axles
- 6 screws 5 x 50 mm
- 6 washers

There is a groove along the bottom side of the treadle rail. In this groove the axles of the treadles will be attached by means of the screws and washers. For each two treadles is one axle and so there are two notches for treadles in between two holes for the screws.



Slide washers over the 5 x 50 mm screws and screw them into the holes of the treadle rail. If you have to mount 10 treadles (Delta with 8 shafts) you don't need the two notches at both ends of the rail and you don't use screws in the first and last hole of the rail.

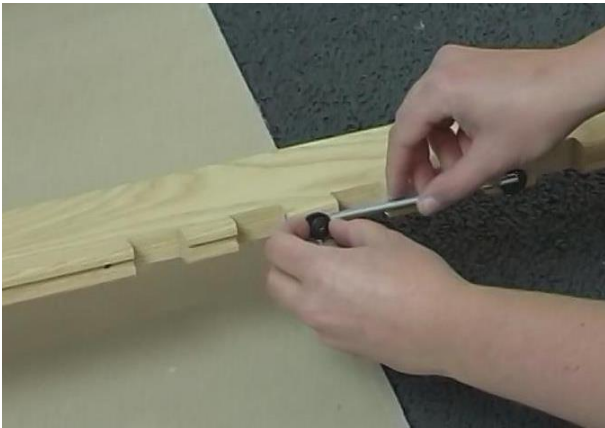

Screw in the screws so far that you just can put the axles behind the washers into the groove.



Position the warp beam section onto the base sides at the rear of the loom, inserting the flexible dowels into the holes of the base sides.



Hook the extenders at both sides with their dowel behind the supports.



The remaining screws from hardware bag 2 are used now to fix the flexible dowel in the base sides.



Insert an axle through the holes of two treadles and place this assembly into two notches of the treadle rail, pushing the axle under the washers into the groove. Mount on next assembly of two treadles and an axle. Every time you mount on next two treadles you can screw on the screws of the last pair of treadles so far the axle is kept in the groove. After all the axles and treadles are in place, you may fix all the screws tightly.

### Assembly of the floating arms and attaching the springs and cords for the moving breast beam



Open hardware bag 3:

- 2 carriage bolts M8 x 75 mm, with big washer, bushing Ø8-12 x 33 mm, small washer and cap nut M8
- 6 screws 4 x 17 mm
- 2 springs with Texsolv cords, 140 cm long
- 2 Texsolv cords, 19,5 cm long

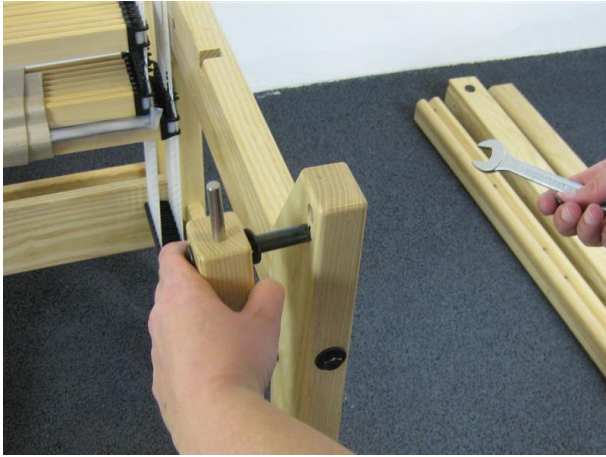

Mount the floating arms at the insides of the front uprights. The marks K and L help you to assemble left and right correctly.

For this hinging joint you have to insert the carriage bolt from the outside (no K or L) through the hole in the arm, then slip on the big washer and the bushing. Insert the assembly through the hole in the upright, slip on the small washer and fasten the assembly with the cap nut.



Four screws 4 x 17 mm have to be screwed into the floating arms. The thread of the screw has to disappear into the wood; the screw heads should protrude  $\pm 4$  mm.



The other two screws 4 x 17 mm have to be screwed into the holes at the rear of the front uprights (also protruding  $\pm 4$  mm).



Use the short Texsolv cords to connect these screws to the upper screws on the floating arms. These cords limit the arms in their movement.



Hook on the springs to the screw eyes at the inside of the main uprights of the Delta.



Lead the spring cords through the screw eyes, underneath the rollers and hook the ends on to the screw head of the floating arm.

### Assembly of the brake of the warp beam



Open hardware bag 4:

- 2 screw eyes Ø12
- 1 carriage bolt M8 x 75 mm with washer Ø 8-25 mm, bushing Ø8-12 x 33 mm, washer Ø8-17 mm and cap nut M8
- 1 carriage bolt M8 x 55 mm with washer Ø 8-25 mm, bushing Ø 8-12 x 12 mm, washer Ø 8-17 mm and cap nut M8
- 1 spring
- 1 brake cable with threaded eye M8 and barrel nut M8
- 10 beam cords
- 1 ratchet wheel
- 4 screws 4 x 30 mm
- 1 pawl
- 1 lag bolt Ø6 x 30 mm
- 2 screws 4 x 13 mm



Screw a screw eye into the brake pedal and the other one into the warp beam support; both so far that the shaft disappears into the wood. The eyes should be parallel to the direction of the wood.



Mount on the pedal to the warp beam support: Insert the carriage bolt M8 x 75 mm from the outside through the hole in the support. Slip over the big washer, then the 33 mm bushing, the brake pedal, the small washer and tighten the assembly with the cap nut.



Hook on the spring to both screw eyes. This goes easier after folding the warp beam section towards the loom.

Unfold the warp beam section again.



The carriage bolt M8 x 55 mm for attaching the brake cable has to be mounted on the warp beam support between the warp beam and the back beam. After inserting the bolt through the support, put on the big washer, the 12 mm bushing and tighten it with the cap nut.



Hook on the loop of the cable to this bolt assembly and wind the cable two times around the disc in the direction as shown on the picture.

Connect the other end of the cable to the pedal: unscrew the barrel nut from the threaded eye and put the threaded end through the slot in the pedal. To screw on the barrel nut again you will need to depress the pedal and replace a winding of the cable aside the disc on the warp beam.

Screw on the barrel nut so far that the thread is protruding about  $\frac{1}{2}$  cm.



To replace the cable into the disc depress the pedal again. Release the pedal while you keep the barrel nut in the half round notch at the bottom side. The position of the pedal should be about horizontal and if not, you can adjust that with the barrel nut repeating this procedure.

### **Installing the cloth beam, the breast beam and attaching the beam cords**



Use the lag bolt to screw pawl at the inside of the right side piece. Tighten the bolt and then release it a bit until the pawl can turn around the bolt freely.

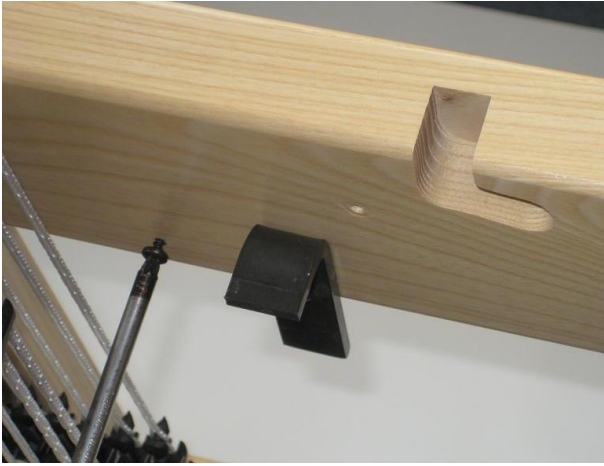

The two round head screws 4 x13mm has to be screwed into the small holes close to the pawl. They are the stops for the movement of the pawl. First screw in the left one; let the long end of the pawl rest on it, and then the other screw.

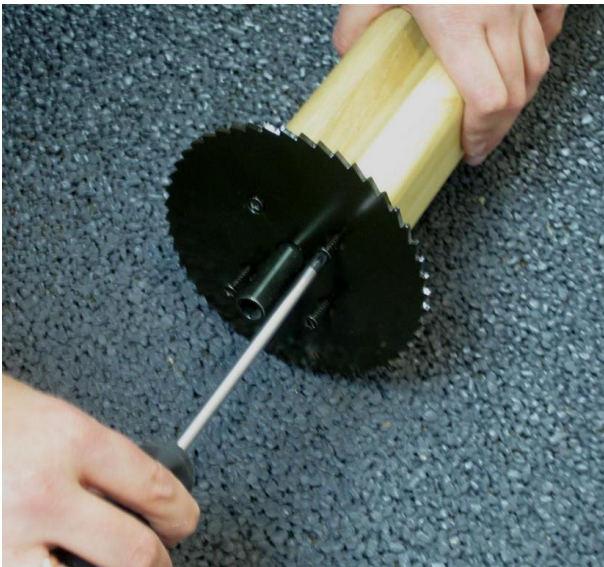

Screw the ratchet wheel onto the cloth beam at the side with the longer axle. Use the four screws 4x30mm; their heads should fit the countersunk holes in the wheel.



Slip the cloth beam lever onto the axle against the ratchet wheel and install this assembly into the loom.



The two holes in the breast beam will fit the metal rods protruding from the floating arms.

Install the breast beam on the rods while keeping the attached cloth protector towards you.



Attach the beam cords to the screw heads of the warp beam and breast beam. If your Delta is 110 cm weaving width, you only need 8 of the 10 cords.

### Assembly of the beater



Open hardware bag 5:

- 2 hinges for the beater uprights
- 2 buffers
- 2 bolts M6 x 75 mm with washer Ø6-17 mm and barrel nut M6
- 2 lag bolts Ø 8 x 90 mm
- 2 bushings Ø8-12 x 33 mm
- 4 washers Ø8-17 mm
- 2 carriage bolts M8 x 75 mm with star knob M8
- 3 plastic strips for beater adjustment.



Screw the hinges into the bottom of the uprights so far that  $\pm 2$  cm of the thread still sticks out. The exact height of the beater can be adjusted later on by screwing the hinges further in or out.

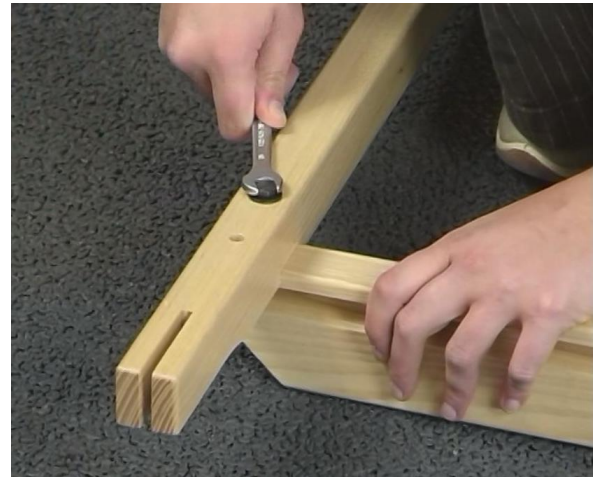

Attach the lower reed holder in the notches of the uprights, using the two m6 x 75 mm bolts, washers, and barrel nuts.



Screw at both sides of the loom a buffer with the threaded end entirely into the wood.

Depending on the number of shafts, you use the first or the second hole for the buffer.

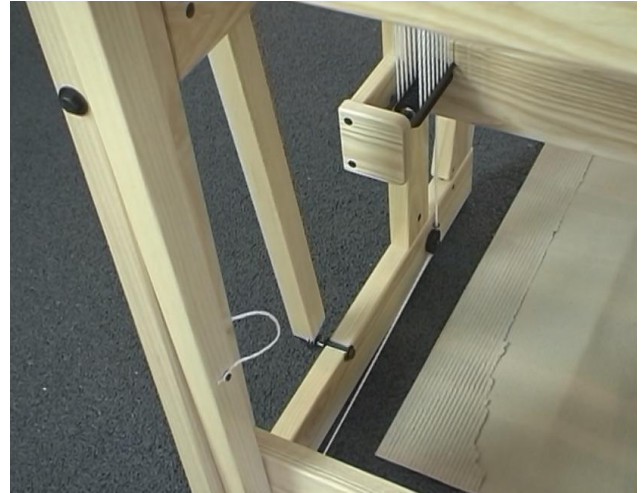

Place the entire assembly, uprights and reed holder onto the loom. By keeping the assembly slightly tilted, you can guide one hinge around the side piece first and then the other. Place the hinges into the grooves on the lower side rails.



Slide a washer onto both lag bolts and insert them into the holes in the upper beater holder. If applicable, choose the nicest side facing the front (the side of the handle). Slide a washer and a steel bushing onto both lag bolts.

Turn the bolts into the handle until the bushings fit tightly against the handle.



Insert the carriage bolts from the backside into the holes at the end of the upper beater bar, screw the star knobs onto the bolts a few turns.

Assemble the top beater bar, placing the bolts into the grooves on top of the uprights.

The square parts of the carriage bolts, held by the groove of the uprights, prevent the bolts from turning, when you tighten the star knobs.

The slots in the beater uprights allow you to install reeds of different heights into the reed holders.



The reed is packed between the lams of the Delta. You can take it out after cutting the straps.



Take the reed out of its plastic bag and install it in between the reed holders.

Now we will check if the beater is even and make a correction if necessary, using the thin plastic strips that you found in hardware bag 5. First check if the hinges protrude the same distance from the bottom of the uprights.



Take the beater by its handle and pull it towards you some cm (1-2").

If the beater is even, both uprights will leave the buffers at the same moment and also touch the buffers at the same time when you let the beater go back and rest against them.

If this is not the case, the beater is not even and you will correct that with the small plastic strips from the hardware bag.

The upright that leaves the buffer latest when you pull the beater, is the one that needs one or more cardboard strips in its slit connection with the lower reed holder.

Unscrew the M6 bolt several turns, so that some play is created in this connection. Slide a cardboard strip completely into the slit at the bottom and fasten the m6 bolt again. Check for evenness again, adding strips in the slit as necessary.



To wind the warp beam, the crank should be inserted into the axle of the warp beam. Of course you have to release the brake by pushing the pedal to turn the warp beam.

### Tying the treadles

In the box with the treadles you also found the locking pin and the tie-up cords for the treadles. There come 60 long and 60 short ones with an 8 –shaft Delta and 120 of each if your Delta has 12 shafts.



Insert the locking pin into the hole in the top rail and through the marked cord loops. Now the shaft bars and lams are fixed in their neutral position.

The tie-up cords are pre-cut in the correct lengths at a spot between two cord loops. The loop where the cord is cut has no strength and the next loop is the first loop to be used.

The longer cords should be used to connect the upper lams to the treadles, the shorter cords should be used to tie the lower lams. Tying-up is easier after removing the cloth beam and the breast beam from the loom.

If a shaft is tied to a treadle by means of its upper lam, the treadle will pull the shaft down, so the tie-ups to the upper lams correspond to the X marks of a weaving draft. If a lower lam is tied to a treadle, the treadle will lift its shaft up, so these tie-ups correspond to the O marks.

Tying-up a countermarch loom, using a weaving draft for a singular tie-up, that only shows X marks, the blank squares are the tie-ups to the lower lams and the other way around, if the weaving draft is showing only O marks, the blank squares are the tie-ups to the upper lams.

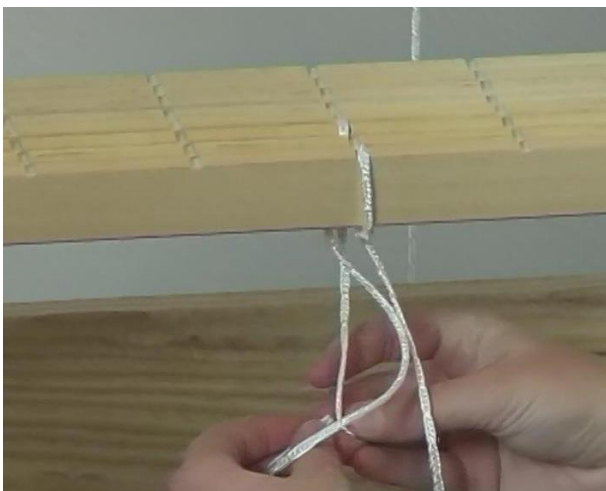

First make the tie-ups to the upper lams. Loop the cord around the lam and pass one end through the last loop in the other end. Tighten it after the cord is positioned in the groove in the lam, right above the treadle to be tied.

The tie-up cords of the upper lams have to pass the lower lams. As a rule these cords pass behind of the lower lam, associated with the same shaft. That will help you to avoid the error of tying-up both the lams of a shaft to the same treadle: In front of each cord passing the lower lams, the groove in the lower lam should not be used for a tie-up. Tie the lower lams to the treadles: Each groove in the lower lams that is not past behind by a cord should be tied to the screw head on the treadle right below.



The cords should be tied to the screw heads on a treadle in a sequence, corresponding to the shafts.

When all the tie-ups are made, check if all the cords are about the same tightness. If there are big differences, you probably misjudged which loop was the last loop of one or more cords. Another cause may be that one or more lam is not fixed to the right level

All shafts will be tied to all treadles used, some to rise and some to fall. If you want to change the tie-up, only unhook the cords from the screw heads and slide the cord over the lam to the groove where you need it. On some lams you will need to add more cords, on some lams they will be left over. You may leave that cords looped over the lams at the sides.

### Adjusting the shaft bars and lams

Shafts and lams are already adjusted of the correct height. They may need a correction after some time.

You can check the correct level after putting the locking pin into the hole at the top of the castle and through the marked loops of the parallel cords. Now the whole system is locked in its neutral position. If the marks on the cords fade, mark them again with a felt pen.

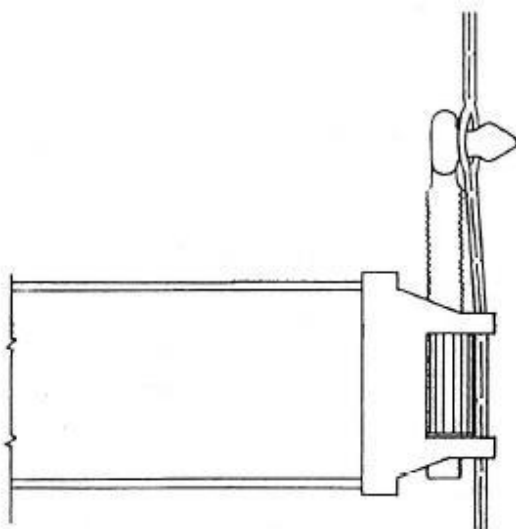

The adjustment of shaft bars and lams can be done in steps of 12 mm, by clicking them into next loop of the cord. For finer adjustment you have to turn the white nut that adjusts the hook, attached to the cord.

The correct height of shafts and lams is easy to understand and therefore easy to keep in mind:

In their neutral position the shafts have to be fixed at the height that the warp on the loom passes through the middle of the heddle eyes. The distance between the shaft bars should be far enough to keep the heddles stretched, but remain moveable along the bars.

The lams should be at such a height, that their tie-ups to the treadles keep the treadles in an angle whereby the row of screw heads is horizontal.

The difference in height of the upper and lower lam has to correspond to the difference in length of the tie-up cords to the treadles.

## Adding or removing heddles

Texsolv heddles consist of a double polyester cord that is connected at specific distances. This chain of heddles is folded in a zigzag fashion into bundles of one hundred. Count the desired number of heddles for each shaft and make bundles by tying the heddles in four places. Always place more heddles than you actually need on each shaft.



To put the heddles on the shafts, the top shaft bar on one side must first be unclipped of the hook with knurled nut and that hook therefore remains in the cord, unlike the older version of the Delta.

Pass the shaft bar through a bunch of heddles and click it back into place. Click the bottom shaft bar off the hook and after putting it through the heddles. Be sure that the bundle is not twisted. Remove the straps from the heddles. Spread the bundle of heddles a bit and click the bottom shaft bar back into place.

Naturally, reverse the steps to remove heddles and don't forget to tie them together at four places, right after you release the tension by unhooking the lower shaft bar.

If your warp doesn't need the whole weaving width of the loom, you can leave the heddles that you don't use on the shafts at the sides.

## The cross sticks

If you are used to leaving the cross sticks in your warp while weaving, the cross sticks should be tied to the screw eyes at the back of the warp beam supports. By doing this, you will avoid the lease sticks following the warp toward the shafts, when you advance the fabric.

Cross sticks in between the back beam and shafts reduce the usable depth of your loom.

## The raddle

The plastic raddle strip on top of the castle has 2 dents to 1 cm (5 dents to the inch). Because the raddle is built up from 10 cm strips with half an opening at each end, you will lack one opening for a loom wide warp. In that situation you have to add some more warp ends into the openings at the outside. The middle of the raddle is marked as a guide for starting to thread the warp.

## Threading through

The warp always should be threaded through the heddles of at least four shafts. Using only two shafts for a tabby, you will overload the shaft bars and lams. Lock the shafts, not in use, in their neutral position.

## Tying the warp to the beams

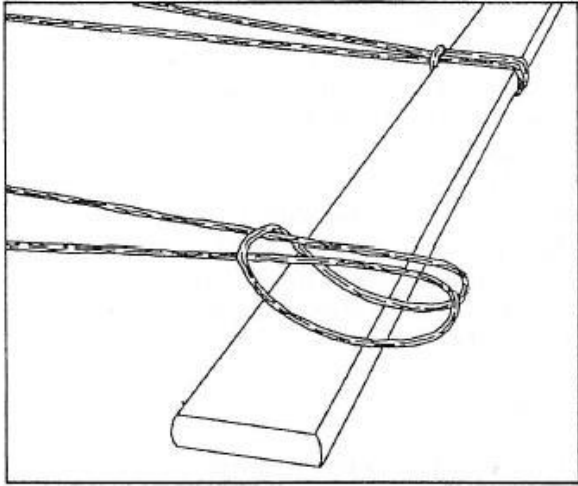

The apron rods are marked at the spots where the cords have to be attached. The diagram shows the usual loop to do this.

After the warp is threaded through the heddles and the reed, the warp ends have to be tied to the apron rod of the cloth beam. For this job the breast beam should be blocked, otherwise it is impossible to get an even tension on all warp ends: Every time you tighten a bundle of threads, the breast will move and release all the other warp ends. When you take the spring cords off the floating arms, the short cords you installed to connect the arms to the loom will block the breast beam.

## Adjusting the warp tension

Release the warp tension after you have tied the warp to the apron rod of the cloth beam, by lifting the brake lever of the warp beam.

By attaching the spring cords to the screw heads at the floating arms you can adjust the tension on the warp: The tighter you tension the cord, the more tension you will get on the warp. Be sure to adjust about the same tension on both sides.

The warp tension should always be judged with the floating arms in the vertical position. The arms move to the front when you advance the cloth beam, and move backwards when you lift the brake lever.

To advance the fabric while weaving, first lift the brake lever. Due to the springs, the breast beam moving toward to you, will pull some warp from the warp beam. Advancing the fabric using the cloth beam lever, you will bring the floating arms back in their vertical position. Now the moving breast beam demonstrates its other feature: The warp tension is automatically the same as it was before you advanced the fabric.

If you advance the fabric too far, first you have to release the warp tension by lifting the brake lever, than you can take both the ratchets out of the ratchet wheel of the cloth beam. Turn the cloth beam back and put in the ratchets again. Now stand at the side of the loom and lift the brake lever turning the warp beam backwards.

## Adjusting the height of the beater

The beater hinges are screwed with their threaded ends into the bottom of the beater supports. This construction allows you to adjust the beater level: Turn the beater hinges in- or outwards. The beater height should be adjusted, so that the lower shed just touches the lower beater bar. So if you use a smaller shuttle for fine yarn, you may adjust the beater a bit higher, because a big shed is not needed. Always be sure that the beater has the same height at both sides. You can check this by making a shed and watching the lower warp ends touch the lower beater bar.

## **Folding the back section**

To fold up the back section of your Delta, you have to move the beater to the front of the loom. Then release the star knobs that hold the extenders. Lift the extender and move the back section towards the loom. Drop the extenders on their supports; the dowels in the extenders will keep the loom folded.

Folded, you can move the Delta through most doors. If the cloth beam lever needs to come down, you have to move the cloth beam a bit backward.

## **Maintenance**

Your Delta loom is easy to maintain. One month after you assembled it, retighten screws, bolts and nuts of the construction, including the part that was already assembled. Thereafter, check all bolts, screws and nuts once a year.

### **Check points for proper functioning of your loom**

- Check the level of the shafts, lams and treadles, while the parallel cords are locked by the pin in their marked loops.
- Check that the parallel cords run through the grooves in the black plastic ends of the lams and shaft bars.
- Check that both the spring cords run in the grooves of their rollers.
- Check that the washers are underneath the wing nuts, where the top beater bar is attached to the supports. If the washer is located in between the beater bar and the support, it will make the beater unstable and the wing nut will damage the wood.

### **When things do not work smoothly**

The shed is poor or hard to make.

May be caused by:

- The treadles are tied too high or too low.
- The lams aren't adjusted at the right level.
- The beater is adjusted too high.
- The lease sticks are in the warp between the shafts and the back beam.
- The fabric should be advanced.
- The tie-up cords to the treadles cross each other.

A treadle cannot be pushed down.

May be caused by:

- The locking pin is still in the parallel cords.
- An error in tying-up the treadle: The treadle is tied-up to both the upper and lower lam of the same shaft.

During tying the warp to the apron bar of the cloth beam, the tension on the warp stays irregular.

May be caused by:

- The spring cords have not been unhooked from the screw eyes of the floating arms.
- One of the extenders is not fixed onto its support.
- The brake cable doesn't run properly over the brake disc or the cable needs to be tightened.
- One of the short cords doesn't block the floating arm.

The warp wouldn't come off from the warp beam.

May be caused by:

- The brake lever has to be lifted further.
- The brake lever is adjusted too high: release the cable a bit.
- While weaving with a very low warp tension, the warp wouldn't pass the cross sticks: Take them out. If that doesn't solve the problem, you have to beam the warp beam by hand, while lifting the brake lever.

The cloth is slanted.

May be caused by:

- One of the wing nuts that hold the warp beam supports came loose.
- The beater is not adjusted on the same level at both sides.
- The tension of the springs is not the same on both sides.
- One of the spring cords has slipped of the roller.

The cloth cannot be advanced.

May be caused by:

- One of the ratchets of the cloth beam is not in the ratchet wheel.
- The apron bar of the cloth beam is caught on one of the floating arms.